

Thermosiphon Heating System TPS



GENERATOR



HEAVY
EQUIPMENT



TRUCK
& BUS



MARINE

HOTSTART's TPS thermosiphon heating system is a coolant preheater, developed to maintain optimal temperatures for diesel and gas engines in stationary land power, marine, construction equipment, and truck applications.

BENEFITS & FEATURES

PROVEN DESIGN

Depend on consistent, reliable heating with the proven design of the TPS Thermosiphon heater. Heated coolant rises through the engine block, maintaining critical fluid temperatures for easy engine starts when needed.

VERSATILE & ADAPTABLE

The TPS can be configured for almost any weather-protected application. Multiple options and voltages are available, including UL/C-US listed and CE-compliant models.

EASY INSTALLATION

The TPS's inlet and outlet positions allow for quick and simple installations, reducing complicated plumbing requirements. Each heater comes with a mounting kit for optimized installations.



Thermosiphon Heating System TPS



GENERATOR



HEAVY
EQUIPMENT



TRUCK
& BUS



MARINE

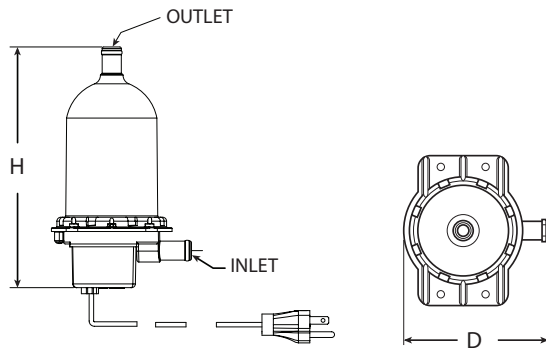

Height (H)	Depth (D)	Weight
7.9"	4.6"	1.7 lbs
200 mm	117 mm	771 g

TPS System	
Phase	single-phase (1 Ø)
Voltage	120V 240V 277V
Ingress	IP41
Tank Material	Polyphenylensulfid PPS
Heating Element Material	Incoloy 800
Min./Max. Ambient Temp.	-4–104 °F (-20–40 °C)
Certification	UL/C-US listed, CE-compliant

TPS Coolant	
Fluid Type	Water Coolant mix (50% water/50% glycol)
Heat Power*	0.5kW 1kW 1.5kW 1.8kW 2kW
Temp. Control	Fixed, 100–120 °F (38–49 °C)
Max. Pressure	90 psi (620 kPa)
Inlet/Outlet	0.625" hose barb (15.9 mm)

Temperature Range		Numerical Code
ON	OFF	
80 °F (27 °C)	100 °F (38 °C)	8
100 °F (38 °C)	120 °F (49 °C)	10
120 °F (49 °C)	140 °F (60 °C)	12

Options shown represent typical tested or certified configurations. Additional options or configurations may be available. For assistance with your heating system application, contact HOTSTART at 509.600.3700 or sales@hotstart.com.

* – 2 kW available in 240 V only, 1.8 kW available in 120 V only.

ORDERING INFORMATION

TPS

Engine Displacement	Power Supply			Heating System		
	V	Ø	Hz	kW	Amps	Model Number
150 CID 2.5 L	120	1	60	0.5	4.2	TPS051GT8-000
	120	1	60	0.5	4.2	TPS051GT10-000
	120	1	60	0.5	4.2	TPS051GT12-000
	240	1	60	0.5	2.1	TPS052GT8-000
	240	1	60	0.5	2.1	TPS052GT10-000
	240	1	60	0.5	2.1	TPS052GT10-013
	240	1	60	0.5	2.1	TPS052GT12-000
350 CID 5.7 L	120	1	60	1	8.4	TPS101GT8-000
	120	1	60	1	8.4	TPS101GT10-000
	120	1	60	1	8.4	TPS101GT12-000
	240	1	60	1	4.2	TPS102GT8-000
	240	1	60	1	4.2	TPS102GT10-000
	240	1	60	1	4.2	TPS102GT10-013
350–500 CID 5.7–8.2 L	120	1	60	1.5	12.5	TPS151GT8-000
	120	1	60	1.5	12.5	TPS151GT10-000
	120	1	60	1.5	12.5	TPS151GT12-000
	240	1	60	1.5	6.3	TPS152GT8-000
	240	1	60	1.5	6.3	TPS152GT10-000
	240	1	60	1.5	6.3	TPS152GT10-013
	240	1	60	1.5	6.3	TPS152GT12-000
500–700 CID 8.2–11.5 L	120	1	60	1.8	15	TPS181GT8-000
	120	1	60	1.8	15	TPS181GT10-000
	120	1	60	1.8	15	TPS181GT12-000
	240	1	60	2	8.3	TPS202GT8-000
	240	1	60	2	8.3	TPS202GT10-000
	240	1	60	2	8.3	TPS202GT10-013
	240	1	60	2	8.3	TPS202GT12-000

Power cord length on all models – 48" (1219 mm)

TPS engine preheaters include a fixed setting thermostat. A single or double digit numeral at the end of the model number prefix designates the temperature range.

Example: TPS101GT10-000

TPS heaters are available with in-line adjustable and remote thread-in fixed thermostat. Please reference HOTSTART's product catalog for part numbers.

-013 Engine preheater features 2 meter round cord & Schuko plug - CE compliant